

REPRESENTATION OF SMALL DIAMETER TOOLS

小孔径刀表示方法

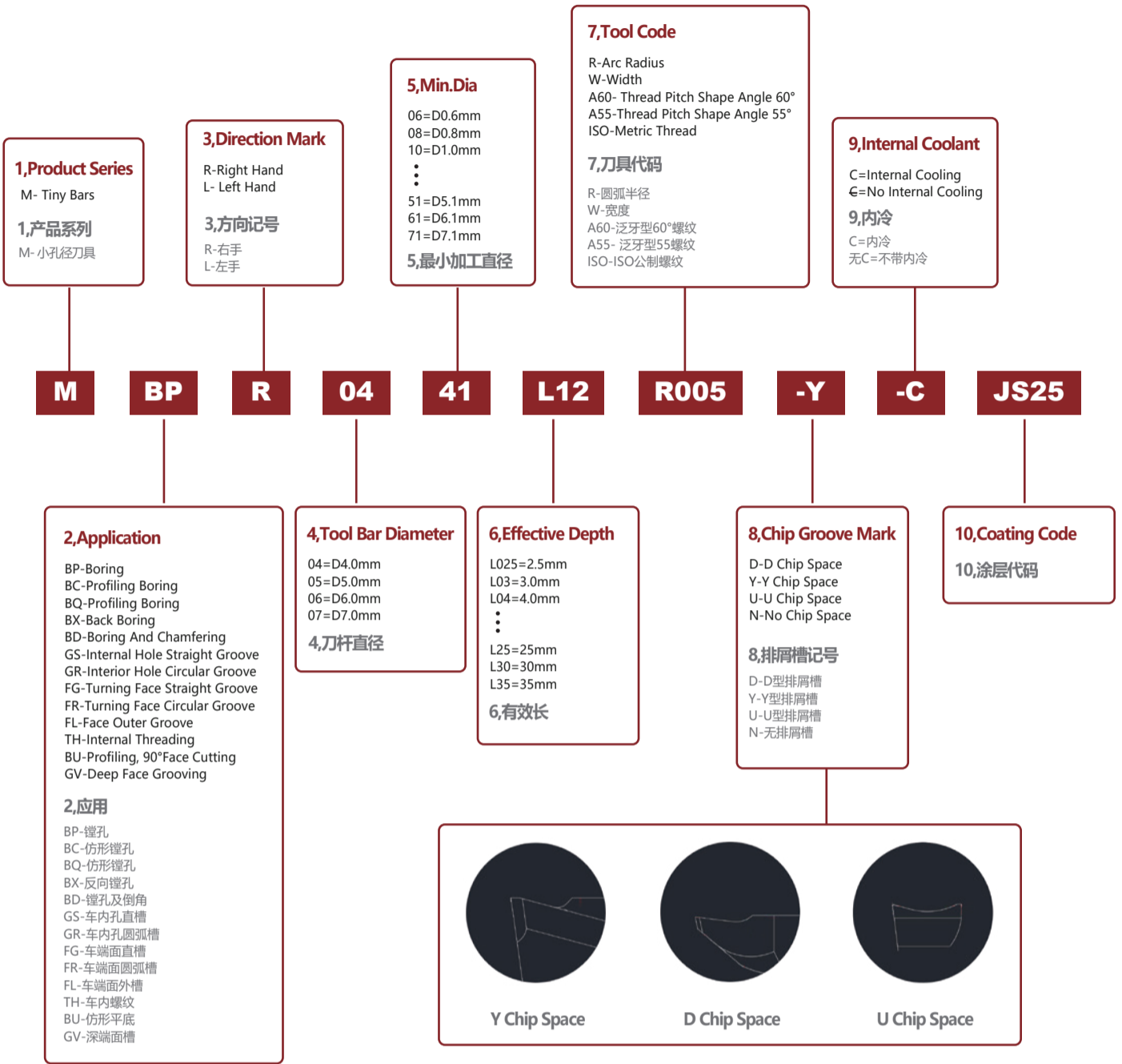

LOCKING PRECISION DESIGN

免对刀套设计 斜柄定位设计

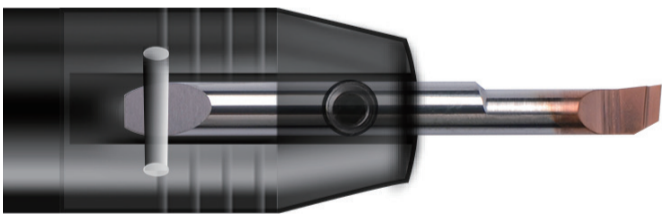

- The solid carbide boring bar fits precisely into the adaptor with a locating pin. Collet-clamped adaptors ensure rigid clamping with increased stability.
- 镗刀斜柄设计，配合定位销钉刀套设计，夹持高精稳定可实现免对刀，提升设备稼动率。

INTERNAL COOLANT

内冷设计

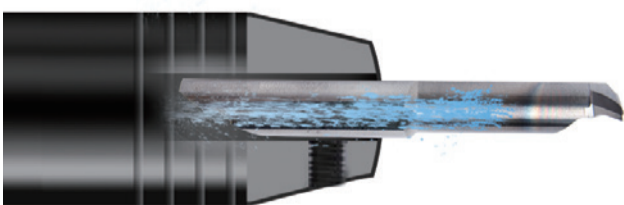

- An internal coolant supply is designed through the side grooves at the rear of the boring tool. Collet clamping adaptors feature selectable coolant orientation for better chip evacuation and safe machining.
- 镗刀斜柄位侧边开槽设计，配合中心出水刀套，实现内冷加工。

MBPR

INTERNAL BORING

内孔镗刀

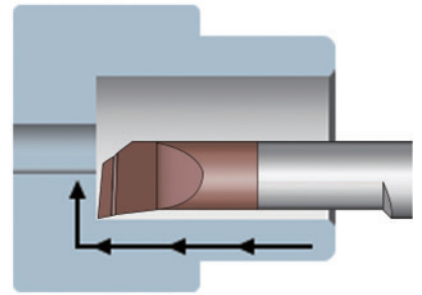
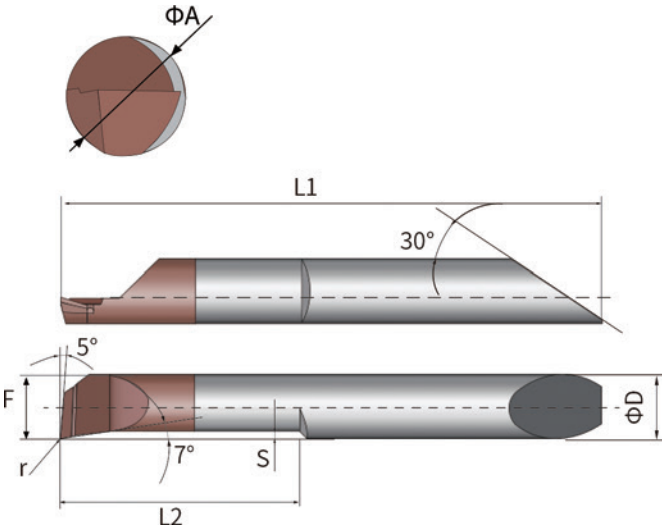

产品型号 Product Type	最小加工直径 Min. Dia (mm) ΦA	ΦD	r	L1	L2	F	S	JS25	AL25
MBPR0421L06R005-Y- (C)	2.1	4	0.05	31	6	1.85	0.2	●	●
MBPR0421L06R010-Y- (C)	2.1	4	0.10	31	6	1.85	0.2	●	●
MBPR0421L10R005-Y- (C)	2.1	4	0.05	35	10	1.85	0.2	●	●
MBPR0421L10R010-Y- (C)	2.1	4	0.10	35	10	1.85	0.2	●	●
MBPR0426L08R005-Y- (C)	2.6	4	0.05	33	8	2.35	0.25	●	●
MBPR0426L08R010-Y- (C)	2.6	4	0.10	33	8	2.35	0.25	●	●
MBPR0426L08R015-Y- (C)	2.6	4	0.15	33	8	2.35	0.25	●	●
MBPR0426L12R005-Y- (C)	2.6	4	0.05	37	12	2.35	0.25	●	●
MBPR0426L12R010-Y- (C)	2.6	4	0.10	37	12	2.35	0.25	●	●
MBPR0426L12R015-Y- (C)	2.6	4	0.15	37	12	2.35	0.25	●	●
MBPR0431L10R005-Y- (C)	3.1	4	0.05	35	10	2.8	0.30	●	●
MBPR0431L10R010-Y- (C)	3.1	4	0.10	35	10	2.8	0.30	●	●
MBPR0431L10R015-Y- (C)	3.1	4	0.15	35	10	2.8	0.30	●	●
MBPR0431L15R005-Y- (C)	3.1	4	0.05	40	15	2.8	0.30	●	●
MBPR0431L15R010-Y- (C)	3.1	4	0.10	40	15	2.8	0.30	●	●
MBPR0431L15R015-Y- (C)	3.1	4	0.15	40	15	2.8	0.30	●	●
MBPR0441L12R005-Y- (C)	4.1	4	0.05	37	12	3.8	0.40	●	●
MBPR0441L12R010-Y- (C)	4.1	4	0.10	37	12	3.8	0.40	●	●
MBPR0441L12R020-Y- (C)	4.1	4	0.20	37	12	3.8	0.40	●	●
MBPR0441L16R005-Y- (C)	4.1	4	0.05	41	16	3.8	0.40	●	●
MBPR0441L16R010-Y- (C)	4.1	4	0.10	41	16	3.8	0.40	●	●
MBPR0441L16R020-Y- (C)	4.1	4	0.20	41	16	3.8	0.40	●	●
MBPR0441L20R005-Y- (C)	4.1	4	0.05	45	20	3.8	0.40	●	●
MBPR0441L20R010-Y- (C)	4.1	4	0.10	45	20	3.8	0.40	●	●
MBPR0441L20R020-Y- (C)	4.1	4	0.20	45	20	3.8	0.40	●	●
MBPR0551L15R010-Y- (C)	5.1	5	0.10	40	15	4.8	0.50	●	●
MBPR0551L15R020-Y- (C)	5.1	5	0.20	40	15	4.8	0.50	●	●
MBPR0551L20R010-Y- (C)	5.1	5	0.10	45	20	4.8	0.50	●	●
MBPR0551L20R020-Y- (C)	5.1	5	0.20	45	20	4.8	0.50	●	●
MBPR0551L25R010-Y- (C)	5.1	5	0.10	50	25	4.8	0.50	●	●
MBPR0551L25R020-Y- (C)	5.1	5	0.20	50	25	4.8	0.50	●	●
MBPR0661L15R010-Y- (C)	6.1	6	0.10	40	15	5.8	0.60	●	●
MBPR0661L15R020-Y- (C)	6.1	6	0.20	40	15	5.8	0.60	●	●
MBPR0661L20R010-Y- (C)	6.1	6	0.10	45	20	5.8	0.60	●	●
MBPR0661L20R020-Y- (C)	6.1	6	0.20	45	20	5.8	0.60	●	●
MBPR0661L25R010-Y- (C)	6.1	6	0.10	50	25	5.8	0.60	●	●
MBPR0661L25R020-Y- (C)	6.1	6	0.20	50	25	5.8	0.60	●	●
MBPR0661L30R010-Y- (C)	6.1	6	0.10	55	30	5.8	0.60	●	●
MBPR0661L30R020-Y- (C)	6.1	6	0.20	55	30	5.8	0.60	●	●
MBPR0771L25R010-Y- (C)	7.1	7	0.10	54	25	6.8	0.70	●	●
MBPR0771L25R020-Y- (C)	7.1	7	0.20	54	25	6.8	0.70	●	●
MBPR0771L35R010-Y- (C)	7.1	7	0.10	64	35	6.8	0.70	●	●
MBPR0771L35R020-Y- (C)	7.1	7	0.20	64	35	6.8	0.70	●	●

MBQR

PROFILING AND BORING

仿形镗刀

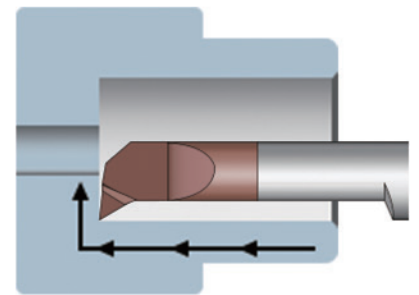
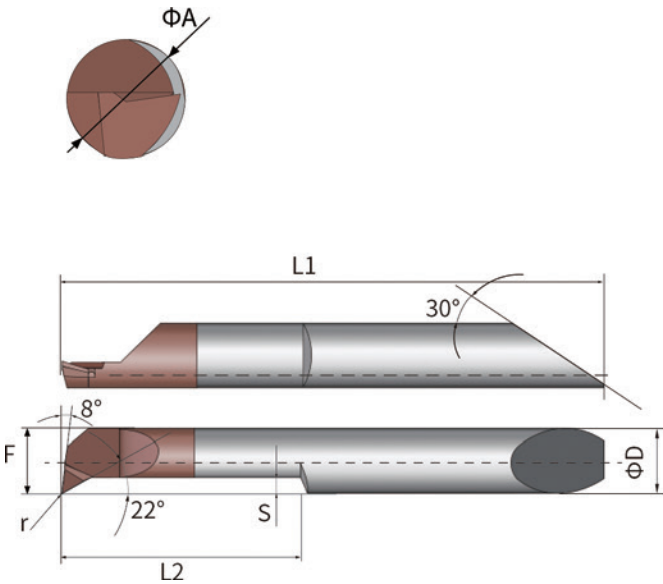

产品型号 Product Type	最小加工直径 Effective diameter (mm) ΦA	ΦD	r	L1	L2	F	S	JS25	AL25
MBQR0404L02R003-D-(C)	0.4	4	0.03	28	2	0.38	0.05	●	●
MBQR0406L02R003-D-(C)	0.6	4	0.03	28	2	0.55	0.06	●	●
MBQR0408L025R003-D-	0.8	4	0.03	28	2.5	0.75	0.08	●	●
MBQR0410L04R005-D-(C)	1	4	0.05	29	4	0.9	0.15	●	●
MBQR0410L04R010-D-(C)	1	4	0.1	29	4	0.9	0.15	●	●
MBQR0410L06R005-D-(C)	1	4	0.05	31	6	0.9	0.15	●	●
MBQR0410L06R010-D-(C)	1	4	0.1	31	6	0.9	0.15	●	●
MBQR0412L04R005-D-(C)	1.2	4	0.05	29	4	1.1	0.15	●	●
MBQR0412L04R010-D-(C)	1.2	4	0.1	29	4	1.1	0.15	●	●
MBQR0412L06R005-D-(C)	1.2	4	0.05	29	6	1.1	0.15	●	●
MBQR0412L06R010-D-(C)	1.2	4	0.1	29	6	1.1	0.15	●	●
MBQR0415L05R005-D-(C)	1.5	4	0.05	30	5	1.4	0.2	●	●
MBQR0415L05R010-D-(C)	1.5	4	0.1	30	5	1.4	0.2	●	●
MBQR0415L08R005-D-(C)	1.5	4	0.05	33	8	1.4	0.2	●	●
MBQR0415L08R010-D-(C)	1.5	4	0.1	33	8	1.4	0.2	●	●
MBQR0418L05R005-D-(C)	1.8	4	0.05	30	5	1.7	0.2	●	●
MBQR0418L05R010-D-(C)	1.8	4	0.1	30	5	1.7	0.2	●	●
MBQR0418L09R005-D-(C)	1.8	4	0.05	34	9	1.7	0.2	●	●
MBQR0418L09R010-D-(C)	1.8	4	0.1	34	9	1.7	0.2	●	●
MBQR0421L06R005-D-(C)	2.1	4	0.05	31	6	1.85	0.25	●	●
MBQR0421L06R010-D-(C)	2.1	4	0.1	31	6	1.85	0.25	●	●
MBQR0421L10R005-D-(C)	2.1	4	0.05	35	10	1.85	0.25	●	●
MBQR0421L10R010-D-(C)	2.1	4	0.1	35	10	1.85	0.25	●	●
MBQR0426L08R005-D-(C)	2.6	4	0.05	33	8	2.35	0.3	●	●
MBQR0426L08R010-D-(C)	2.6	4	0.1	33	8	2.35	0.3	●	●
MBQR0426L08R015-D-(C)	2.6	4	0.15	33	8	2.35	0.3	●	●
MBQR0426L12R005-D-(C)	2.6	4	0.05	37	12	2.35	0.3	●	●
MBQR0426L12R010-D-(C)	2.6	4	0.1	37	12	2.35	0.3	●	●
MBQR0426L12R015-D-(C)	2.6	4	0.15	37	12	2.35	0.3	●	●
MBQR0426L15R005-D-(C)	2.6	4	0.05	40	15	2.35	0.3	●	●
MBQR0426L15R010-D-(C)	2.6	4	0.1	40	15	2.35	0.3	●	●
MBQR0426L15R015-D-(C)	2.6	4	0.15	40	15	2.35	0.3	●	●
MBQR0431L10R005-D-(C)	3.1	4	0.05	35	10	2.8	0.5	●	●

产品型号 Product Type	最小加工直径 Effective diameter (mm) ΦA	ΦD	r	L1	L2	F	S	JS25	AL25
MBQR0431L10R010-D-(C)	3.1	4	0.1	35	10	2.8	0.5	●	●
MBQR0431L10R015-D-(C)	3.1	4	0.15	35	10	2.8	0.5	●	●
MBQR0431L15R005-D-(C)	3.1	4	0.05	40	15	2.8	0.5	●	●
MBQR0431L15R010-D-(C)	3.1	4	0.1	40	15	2.8	0.5	●	●
MBQR0431L15R015-D-(C)	3.1	4	0.15	40	15	2.8	0.5	●	●
MBQR0431L20R005-D-(C)	3.1	4	0.05	45	20	2.8	0.5	●	●
MBQR0431L20R010-D-(C)	3.1	4	0.1	45	20	2.8	0.5	●	●
MBQR0431L20R015-D-(C)	3.1	4	0.15	45	20	2.8	0.5	●	●
MBQR0441L12R005-D-(C)	4.1	4	0.05	37	12	3.8	0.6	●	●
MBQR0441L12R010-D-(C)	4.1	4	0.1	37	12	3.8	0.6	●	●
MBQR0441L12R020-D-(C)	4.1	4	0.2	37	12	3.8	0.6	●	●
MBQR0441L16R005-D-(C)	4.1	4	0.05	41	16	3.8	0.6	●	●
MBQR0441L16R010-D-(C)	4.1	4	0.1	41	16	3.8	0.6	●	●
MBQR0441L16R020-D-(C)	4.1	4	0.2	41	16	3.8	0.6	●	●
MBQR0441L20R005-D-(C)	4.1	4	0.05	45	20	3.8	0.6	●	●
MBQR0441L20R010-D-(C)	4.1	4	0.1	45	20	3.8	0.6	●	●
MBQR0441L20R020-D-(C)	4.1	4	0.2	45	20	3.8	0.6	●	●
MBQR0441L25R015-D-(C)	4.1	4	0.15	50	25	3.8	0.6	●	●
MBQR0551L15R005-D-(C)	5.1	5	0.05	40	15	4.8	0.8	●	●
MBQR0551L15R010-D-(C)	5.1	5	0.1	40	15	4.8	0.8	●	●
MBQR0551L15R020-D-(C)	5.1	5	0.2	40	15	4.8	0.8	●	●
MBQR0551L20R005-D-(C)	5.1	5	0.05	45	20	4.8	0.8	●	●
MBQR0551L20R010-D-(C)	5.1	5	0.1	45	20	4.8	0.8	●	●
MBQR0551L20R020-D-(C)	5.1	5	0.2	45	20	4.8	0.8	●	●
MBQR0551L25R005-D-(C)	5.1	5	0.05	50	25	4.8	0.8	●	●
MBQR0551L25R010-D-(C)	5.1	5	0.1	50	25	4.8	0.8	●	●
MBQR0551L25R020-D-(C)	5.1	5	0.2	50	25	4.8	0.8	●	●
MBQR0551L30R020-D-(C)	5.1	5	0.2	55	30	4.8	0.8	●	●
MBQR0661L15R005-D-(C)	6.1	6	0.05	40	15	5.8	1	●	●
MBQR0661L15R010-D-(C)	6.1	6	0.1	40	15	5.8	1	●	●
MBQR0661L15R020-D-(C)	6.1	6	0.2	40	15	5.8	1	●	●
MBQR0661L20R005-D-(C)	6.1	6	0.05	45	20	5.8	1	●	●
MBQR0661L20R010-D-(C)	6.1	6	0.1	45	20	5.8	1	●	●
MBQR0661L20R020-D-(C)	6.1	6	0.2	45	20	5.8	1	●	●
MBQR0661L25R005-D-(C)	6.1	6	0.05	50	25	5.8	1	●	●
MBQR0661L25R010-D-(C)	6.1	6	0.1	50	25	5.8	1	●	●
MBQR0661L25R020-D-(C)	6.1	6	0.2	50	25	5.8	1	●	●
MBQR0661L30R005-D-(C)	6.1	6	0.05	55	30	5.8	1	●	●
MBQR0661L30R010-D-(C)	6.1	6	0.1	55	30	5.8	1	●	●
MBQR0661L30R020-D-(C)	6.1	6	0.2	55	30	5.8	1	●	●
MBQR0661L35R020-D-(C)	6.1	6	0.2	60	35	5.8	1	●	●
MBQR0771L25R010-D-(C)	7.1	7	0.1	54	25	6.8	1.2	●	●
MBQR0771L25R020-D-(C)	7.1	7	0.2	54	25	6.8	1.2	●	●
MBQR0771L35R010-D-(C)	7.1	7	0.1	64	35	6.8	1.2	●	●
MBQR0771L35R020-D-(C)	7.1	7	0.2	64	35	6.8	1.2	●	●
MBQR0771L40R020-D-(C)	7.1	7	0.2	69	40	6.8	1.2	●	●
MBQR0771L50R020-D-(C)	7.1	7	0.2	79	50	6.8	1.2	●	●

● 有库存 (C) 代表可内冷定制 ● on stock (C) Internal cooling customization

MBUR

PROFILING, 90° FACE CUTTING 仿形平底镗刀

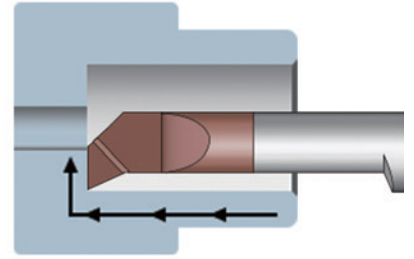
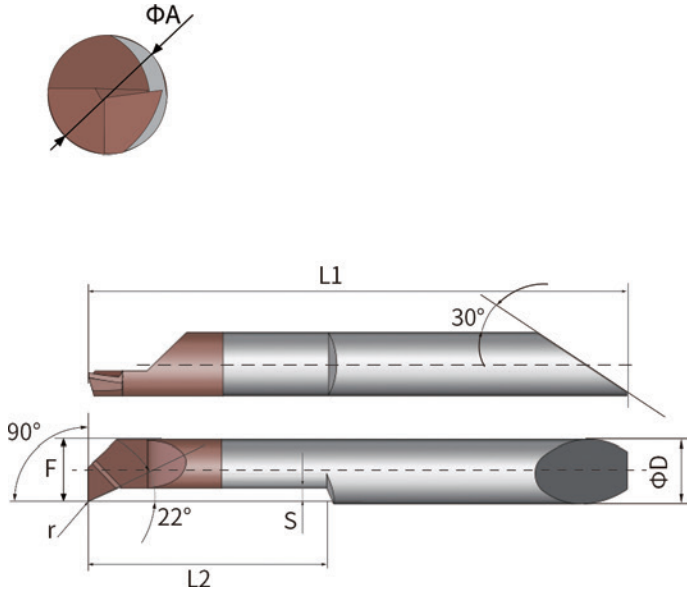

产品型号 Product Type	最小加工直径 Min. Dia (mm) ΦA	ΦD	r	L1	L2	F	S	JS25	AL25
MBUR0431L10R010-D-(C)	3.1	4	0.10	35	10	2.8	0.40	●	●
MBUR0441L12R010-D-(C)	4.1	4	0.10	37	12	3.8	0.50	●	●
MBUR0551L15R015-D-(C)	5.1	5	0.15	40	15	4.8	0.70	●	●
MBUR0661L20R015-D-(C)	6.1	6	0.15	45	20	5.8	0.90	●	●

● 有库存 (C)代表可内冷定制 ● on stock (C) Internal cooling customization

MBCR

PROFILING AND BORING 仿形镗刀

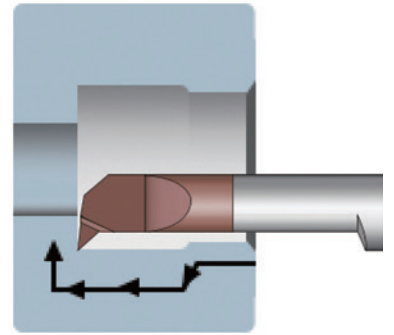
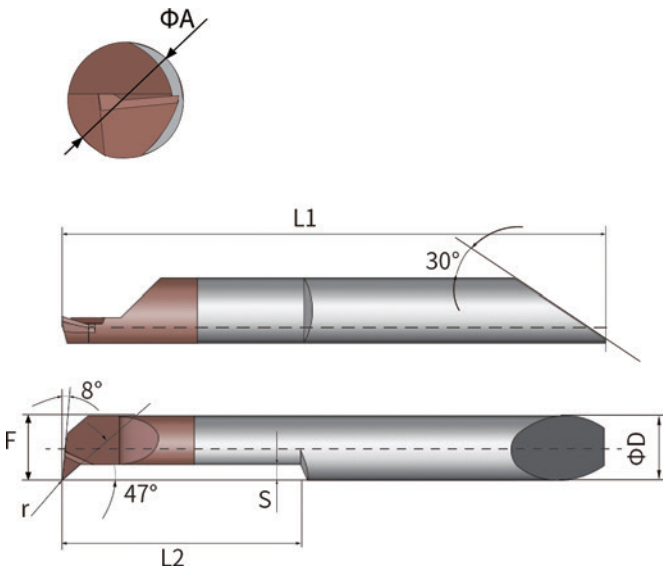

产品型号 Product Type	最小加工直径 Effective diameter (mm) ΦA	ΦD	r	L1	L2	F	S	JS25	AL25
MBCR0415L05R005-D-(C)	1.5	4	0.05	30	5	1.4	0.3	●	●
MBCR0421L06R005-D-(C)	2.1	4	0.05	31	6	1.85	0.4	●	●
MBCR0426L08R005-D-(C)	2.6	4	0.05	33	8	2.35	0.45	●	●
MBCR0431L10R005-D-(C)	3.1	4	0.05	35	10	2.8	0.6	●	●
MBCR0431L10R010-D-(C)	3.1	4	0.1	35	10	2.8	0.6	●	●
MBCR0431L15R005-D-(C)	3.1	4	0.05	37	15	2.8	0.6	●	●
MBCR0431L15R010-D-(C)	3.1	4	0.1	37	15	2.8	0.6	●	●
MBCR0441L12R005-D-(C)	4.1	4	0.05	37	12	3.8	0.8	●	●
MBCR0441L12R010-D-(C)	4.1	4	0.1	37	12	3.8	0.8	●	●
MBCR0441L16R005-D-(C)	4.1	4	0.05	41	16	3.8	0.8	●	●
MBCR0441L16R010-D-(C)	4.1	4	0.1	41	16	3.8	0.8	●	●
MBCR0441L20R005-D-(C)	4.1	4	0.05	45	20	3.8	0.8	●	●
MBCR0441L20R010-D-(C)	4.1	4	0.1	45	20	3.8	0.8	●	●
MBCR0551L20R005-D-(C)	5.1	5	0.05	45	20	4.8	1	●	●
MBCR0551L20R015-D-(C)	5.1	5	0.15	45	20	4.8	1	●	●
MBCR0551L25R005-D-(C)	5.1	5	0.05	50	25	4.8	1	●	●
MBCR0551L25R015-D-(C)	5.1	5	0.15	50	25	4.8	1	●	●
MBCR0661L20R005-D-(C)	6.1	6	0.05	45	20	5.8	1.2	●	●
MBCR0661L20R015-D-(C)	6.1	6	0.15	45	20	5.8	1.2	●	●
MBCR0661L25R005-D-(C)	6.1	6	0.05	50	25	5.8	1.2	●	●
MBCR0661L25R015-D-(C)	6.1	6	0.15	50	25	5.8	1.2	●	●
MBCR0661L30R005-D-(C)	6.1	6	0.05	55	30	5.8	1.2	●	●
MBCR0661L30R015-D-(C)	6.1	6	0.15	55	30	5.8	1.2	●	●

● 有库存 (C)代表可内冷定制 ● on stock (C) Internal cooling customization

MBXR

REVERSE BORING CUTTER 反向镗刀

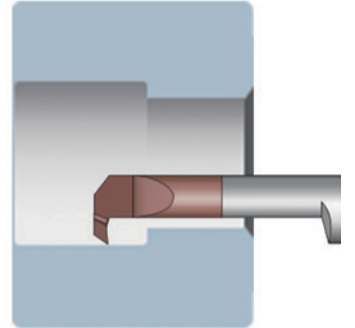
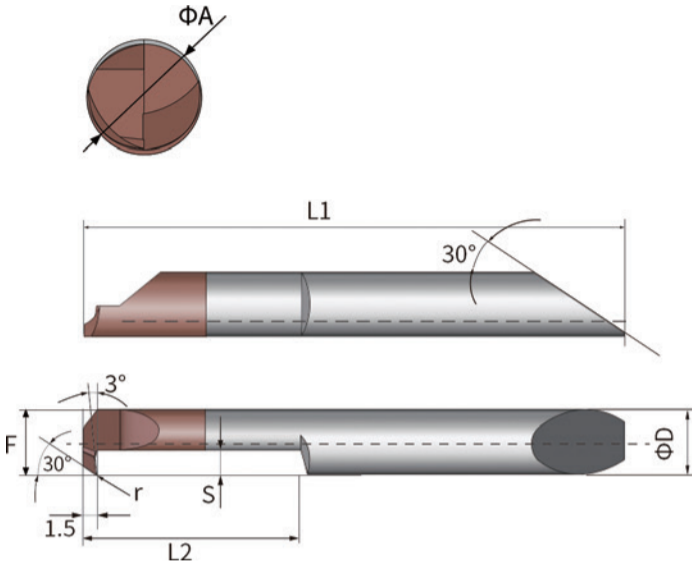

产品型号 Product Type	最小加工直径 Min. Dia (mm) ΦA	ΦD	r	L1	L2	F	S	JS25	AL25
MBXR0441L16R010-D-(C)	4.1	4	0.10	41	16	3.8	1.00	●	●
MBXR0551L20R010-D-(C)	5.1	5	0.10	45	20	4.8	1.30	●	●
MBXR0661L25R010-D-(C)	6.1	6	0.10	50	25	5.8	1.60	●	●

● 有库存 (C) 代表可内冷定制 ● on stock (C) Internal cooling customization

MFGR

FACE GROOVING 端面槽刀

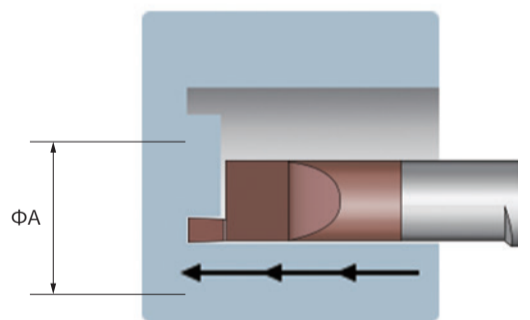
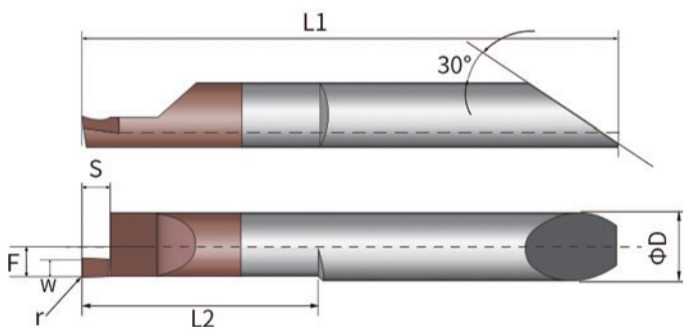

产品型号 Product Type	最小加工直径 Min. Dia (mm) ΦA	ΦD	r	L1	L2	F	S	W	JS25	AL25
MFGR0450L12W050-U-(C)	5.0	4	0.05	37	12	1.9	1.00	0.50	●	●
MFGR0450L12W100-U-(C)	5.0	4	0.05	37	12	1.9	1.50	1.00	●	●
MFGR0450L12W150-U-(C)	5.0	4	0.05	37	12	1.9	2.00	1.50	●	●
MFGR0560L15W100-U-(C)	6.0	5	0.10	40	15	2.4	1.50	1.00	●	●
MFGR0560L15W150-U-(C)	6.0	5	0.10	40	15	2.4	2.50	1.50	●	●
MFGR0560L15W200-U-(C)	6.0	5	0.10	40	15	2.4	3.00	2.00	●	●
MFGR0680L20W100-U-(C)	8.0	6	0.10	45	20	2.9	2.00	1.00	●	●
MFGR0680L20W150-U-(C)	8.0	6	0.10	45	20	2.9	2.50	1.50	●	●
MFGR0680L20W200-U-(C)	8.0	6	0.10	45	20	2.9	3.00	2.00	●	●
MFGR0680L20W300-U-(C)	8.0	6	0.10	45	20	2.9	4.50	3.00	●	●

● 有库存 (C) 代表可内冷定制 ● on stock (C) Internal cooling customization

MFGL

FACE GROOVING

端面槽刀

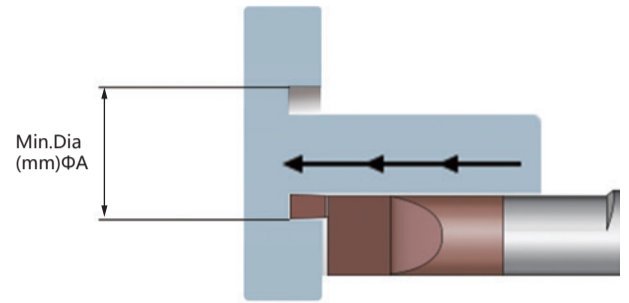
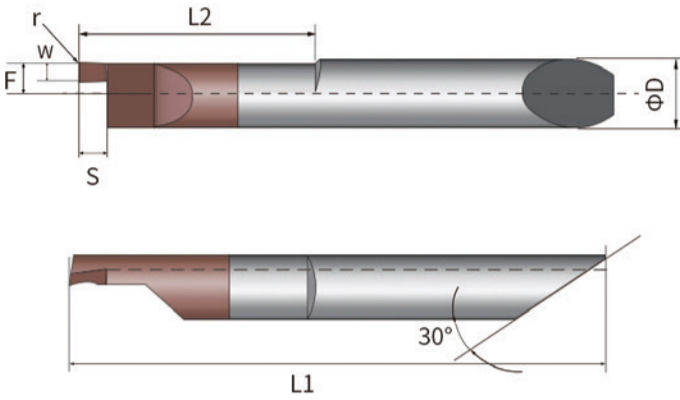

产品型号 Product Type	最小加工直径 Min.Dia (mm) ΦA	ΦD	r	L1	L2	F	S	W	JS25	AL25
MFGL0662L20W080-U-(C)	6.2	6	0.05	45	20	2.9	1.80	0.80	●	●
MFGL0662L20W100-U-(C)	6.2	6	0.05	45	20	2.9	2.00	1.00	●	●
MFGL0662L20W150-U-(C)	6.2	6	0.10	45	20	2.9	3.00	1.50	●	●
MFGL0662L20W200-U-(C)	6.2	6	0.10	45	20	2.9	4.00	2.00	●	●
MFGL0662L20W250-U-(C)	6.2	6	0.10	45	20	2.9	5.00	2.50	●	●

● 有库存 (C)代表可内冷定制 ● on stock (C) Internal cooling customization

MGVR

DEEP FACE GROOVING

深端面槽刀

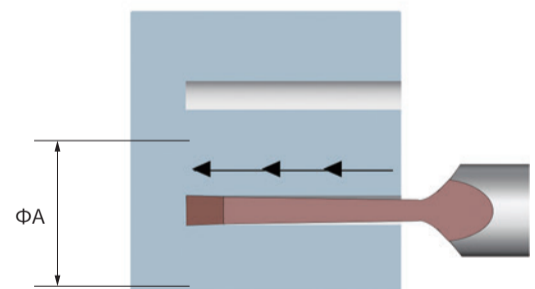
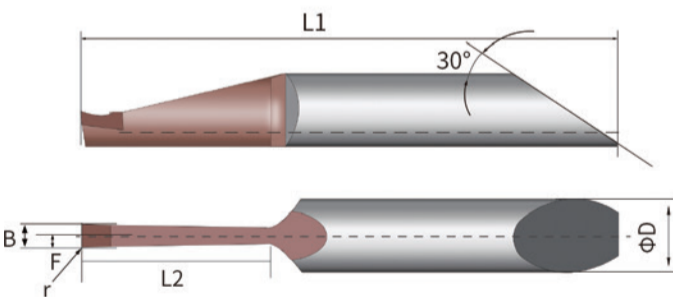

产品型号 Product Type	最小加工环径 Min.Dia (mm) ΦA	ΦD	r	L1	L2	B	F	JS25	AL25
MGVR0712L15W200-U-(C)	12	7	0.2	47	15	2.0	1.1	●	●
MGVR0712L15W250-U-(C)	12	7	0.2	47	15	2.5	1.4	●	●
MGVR0712L15W300-U-(C)	12	7	0.2	47	15	3.0	1.6	●	●

● 有库存 (C)代表可内冷定制 ● on stock (C) Internal cooling customization

MGSR

INTERNAL GROOVING 内孔切槽刀

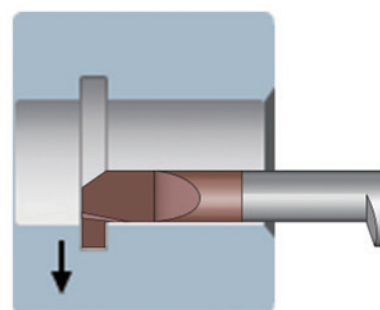
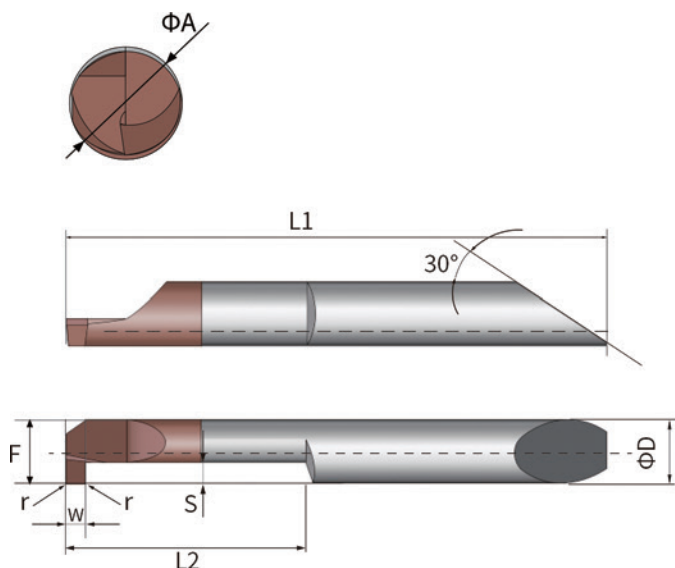

产品型号 Product Type	最小加工直径 Min. Dia (mm) ΦA	ΦD	r±0.01	L1	L2	F	S	W	JS25	AL25
MGSR0426L05W050-D-(C)	2.6	4	0.05	30	5	2.35	0.65	0.50	●	●
MGSR0426L05W075-D-(C)	2.6	4	0.05	30	5	2.35	0.65	0.75	●	●
MGSR0431L05W050-D-(C)	3.1	4	0.05	30	5	2.8	0.80	0.50	●	●
MGSR0431L05W075-D-(C)	3.1	4	0.05	30	5	2.8	0.80	0.75	●	●
MGSR0431L05W100-D-(C)	3.1	4	0.05	30	5	2.8	0.80	1.00	●	●
MGSR0431L10W050-D-(C)	3.1	4	0.05	35	10	2.8	0.80	0.50	●	●
MGSR0431L10W075-D-(C)	3.1	4	0.05	35	10	2.8	0.80	0.75	●	●
MGSR0431L10W100-D-(C)	3.1	4	0.05	35	10	2.8	0.80	1.00	●	●
MGSR0441L06W050-D-(C)	4.1	4	0.05	31	6	3.8	1.00	0.50	●	●
MGSR0441L06W075-D-(C)	4.1	4	0.05	31	6	3.8	1.00	0.75	●	●
MGSR0441L06W100-D-(C)	4.1	4	0.05	31	6	3.8	1.00	1.00	●	●
MGSR0441L06W150-D-(C)	4.1	4	0.05	31	6	3.8	1.00	1.50	●	●
MGSR0441L12W050-D-(C)	4.1	4	0.05	37	12	3.8	1.00	0.50	●	●
MGSR0441L12W075-D-(C)	4.1	4	0.05	37	12	3.8	1.00	0.75	●	●
MGSR0441L12W100-D-(C)	4.1	4	0.05	37	12	3.8	1.00	1.00	●	●
MGSR0441L12W150-D-(C)	4.1	4	0.05	37	12	3.8	1.00	1.50	●	●
MGSR0551L08W100-D-(C)	5.1	5	0.10	33	8	4.8	1.50	1.00	●	●
MGSR0551L08W150-D-(C)	5.1	5	0.10	33	8	4.8	1.50	1.50	●	●
MGSR0551L08W200-D-(C)	5.1	5	0.10	33	8	4.8	1.50	2.00	●	●
MGSR0551L15W100-D-(C)	5.1	5	0.10	40	15	4.8	1.50	1.00	●	●
MGSR0551L15W150-D-(C)	5.1	5	0.10	40	15	4.8	1.50	1.50	●	●
MGSR0551L15W200-D-(C)	5.1	5	0.10	40	15	4.8	1.50	2.00	●	●
MGSR0661L10W100-D-(C)	6.1	6	0.10	35	10	5.8	2.00	1.00	●	●
MGSR0661L10W150-D-(C)	6.1	6	0.10	35	10	5.8	2.00	1.50	●	●
MGSR0661L10W200-D-(C)	6.1	6	0.10	35	10	5.8	2.00	2.00	●	●
MGSR0661L20W100-D-(C)	6.1	6	0.10	45	20	5.8	2.00	1.00	●	●
MGSR0661L20W150-D-(C)	6.1	6	0.10	45	20	5.8	2.00	1.50	●	●
MGSR0661L20W200-D-(C)	6.1	6	0.10	45	20	5.8	2.00	2.00	●	●
MGSR0771L25W100-D-(C)	7.1	7	0.10	54	25	6.8	2.00	1.00	●	●
MGSR0771L25W150-D-(C)	7.1	7	0.10	54	25	6.8	2.00	1.50	●	●
MGSR0771L25W200-D-(C)	7.1	7	0.10	54	25	6.8	2.00	2.00	●	●

● 有库存 (C) 代表可内冷定制 ● on stock (C) Internal cooling customization

MTHR

INTERNAL THREADING 内孔螺纹刀

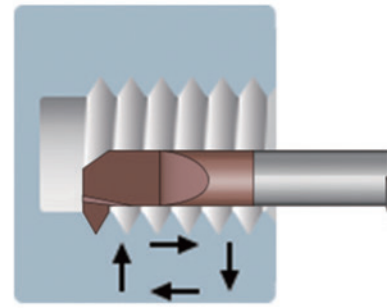
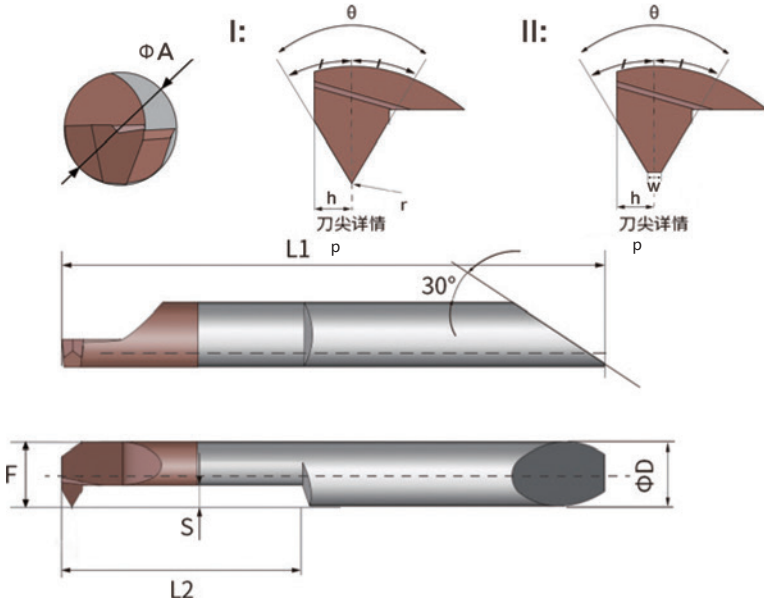

60° 范围牙

产品型号 Product Type	最小加工直径 Min. Dia (mm) ΦA	ΦD	w	r	h	L1	L2	F	S	θ	Pitch Range 螺距范围(mm)	Type 类型	JS25	AL25
MTHR0415L04A60-D- (C)	1.5	4	0.03	/	0.25	29	4	1.4	0.4	60°	P0.25~P0.4	II	●	●
MTHR0420L06A60-D- (C)	2.0	4	0.04	/	0.305	31	6	1.9	0.5	60°	P0.3~P0.5	II	●	●
MTHR0425L08A60-D- (C)	2.5	4	0.06	/	0.375	33	8	2.4	0.6	60°	P0.4~P0.6	II	●	●
MTHR0430L10A60-D- (C)	3.0	4	/	0.05	0.605	35	10	2.9	1.0	60°	P0.5~P0.8	I	●	●
MTHR0441L12A60X-D- (C)	4.1	4	/	0.05	0.72	37	12	3.9	1.2	60°	P0.5~P1.0	I	●	●
MTHR0441L12A60-D- (C)	4.1	4	/	0.10	0.75	37	12	3.9	1.2	60°	P1.0~P1.5	I	●	●
MTHR0551L15A60X-D- (C)	5.1	5	/	0.05	0.895	40	15	4.9	1.5	60°	P0.5~P1.0	I	●	●
MTHR0551L15A60-D- (C)	5.1	5	/	0.10	0.925	40	15	4.9	1.5	60°	P1.0~P1.5	I	●	●
MTHR0661L20A60X-D- (C)	6.1	6	/	0.05	1.07	45	20	5.9	1.8	60°	P0.5~P1.0	I	●	●
MTHR0661L20A60-D- (C)	6.1	6	/	0.10	1.095	45	20	5.9	1.8	60°	P1.0~P1.75	I	●	●

● 有库存 (C) 代表可内冷定制 ● on stock (C) Internal cooling customization

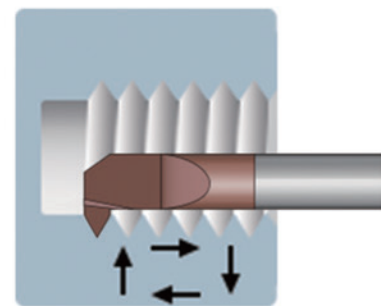
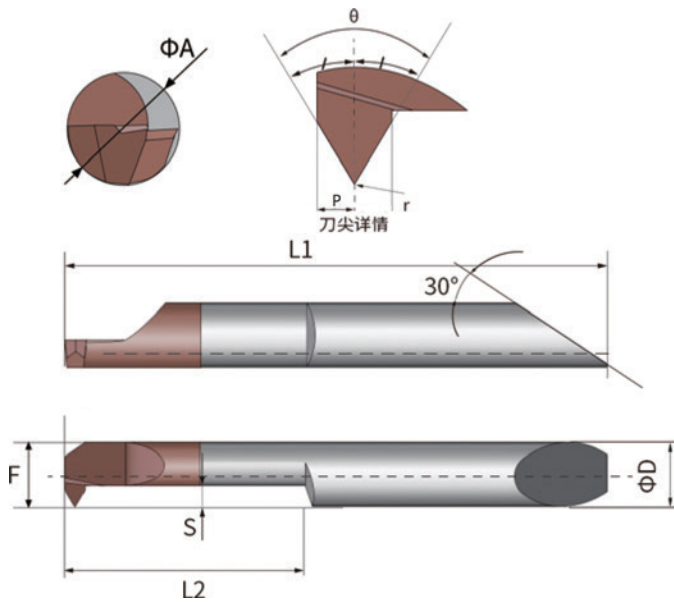

55° 范围牙

产品型号 Product Type	最小加工直径 Min. Dia (mm) ΦA	ΦD	r	p	L1	L2	F	S	θ	TPI 可加工每英寸牙数范围	JS25	AL25
MTHR0431L10A55-D- (C)	3.1	4	0.05	0.55	35	10	2.9	1.0	55°	48-24	●	●
MTHR0441L12A55-D- (C)	4.1	4	0.05	0.655	37	12	3.9	1.2	55°	48-24	●	●
MTHR0551L15A55-D- (C)	5.1	5	0.08	0.865	40	15	4.9	1.6	55°	48-16	●	●
MTHR0661L20A55-D- (C)	6.1	6	0.08	1.04	45	20	5.9	1.9	55°	48-12	●	●
MTHR0771L25A55-D- (C)	7.1	7	0.15	1.13	54	25	7.9	2.5	55°	26-11	●	●

● 有库存 (C) 代表可内冷定制 ● on stock (C) Internal cooling customization

MTHL

INTERNAL THREADING 内孔螺纹刀

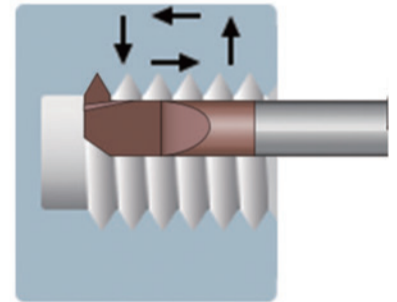
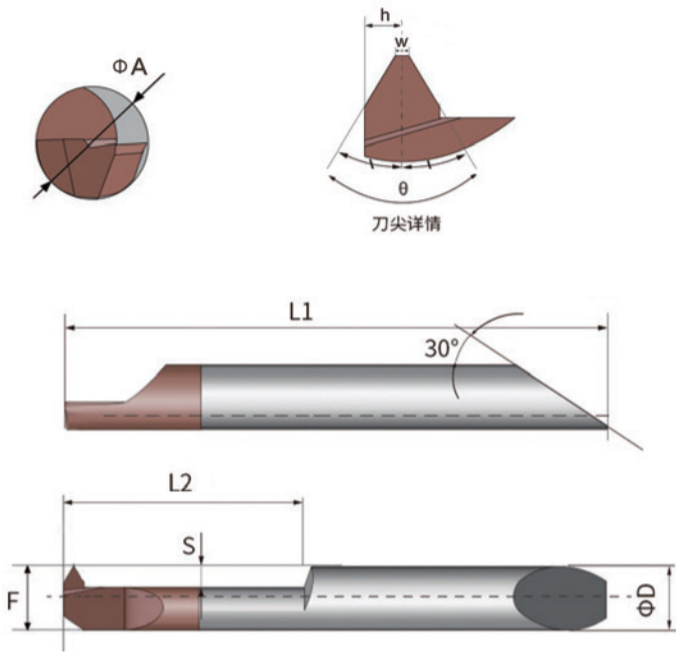

60° 范围牙左手刀

产品型号 Product Type	最小加工直径 Min. Dia (mm) ΦA	ΦD	w	h	L1	L2	F	S	θ	Pitch Range 螺距范围(mm)	JS25	AL25
MTHL0441L12A60X-D- (C)	4.1	4	0.05	0.72	37	12	3.9	1.2	60°	P0.5~P0.8	●	●
MTHL0441L12A60-D- (C)	4.1	4	0.1	0.75	37	12	3.9	1.2	60°	P0.8~P1.0	●	●
MTHL0551L15A60X-D- (C)	5.1	5	0.06	0.895	40	15	4.9	1.5	60°	P0.5~P1.0	●	●
MTHL0551L15A60-D- (C)	5.1	5	0.12	0.925	40	15	4.9	1.5	60°	P1.0~P1.5	●	●
MTHL0661L20A60X-D- (C)	6.1	6	0.08	1.07	45	20	5.9	1.8	60°	P0.5~P1.0	●	●
MTHL0661L20A60-D- (C)	6.1	6	0.16	1.095	45	20	5.9	1.8	60°	P1.0~P1.75	●	●

● 有库存 (C) 代表可内冷定制 ● on stock (C) Internal cooling customization

MFWR

SPHERICAL AND FACE PROFILING BORING 内孔球面·端面·仿形镗刀

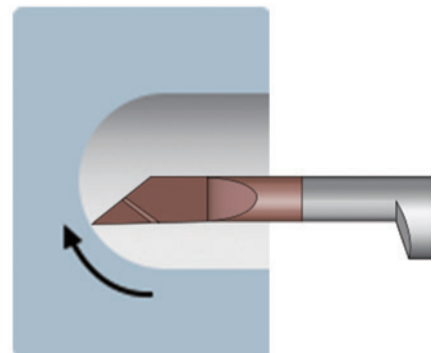
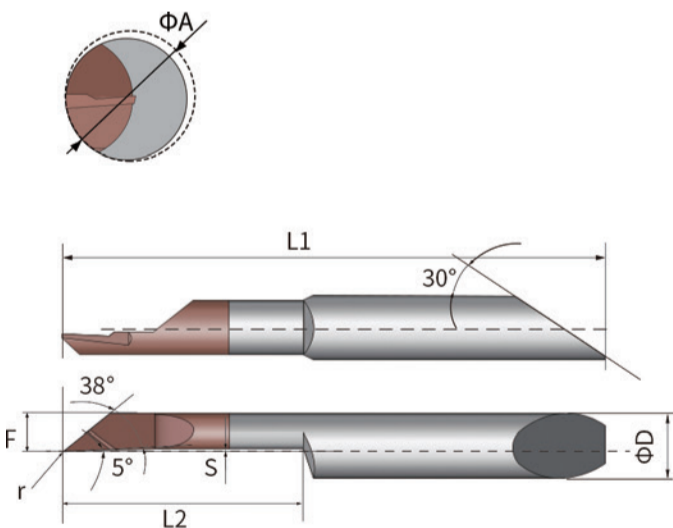

产品型号 Product Type	最小加工直径 Min. Dia (mm) ΦA	ΦD	r	L1	L2	F	S	JS25	AL25
MFWR0435L08R010-D- (C)	3.5	4	0.10	33	8	1.55	0.15	●	●
MFWR0445L10R010-D- (C)	4.5	4	0.10	35	10	1.95	0.25	●	●
MFWR0555L12R010-D- (C)	5.5	5	0.10	38	12	2.45	0.30	●	●
MFWR0665L15R010-D- (C)	6.5	6	0.10	40	15	2.95	0.35	●	●

● 有库存 (C) 代表可内冷定制 ● on stock (C) Internal cooling customization

TINY TOOLS TOOLHOLDERS

微型小镗刀变径套刀杆

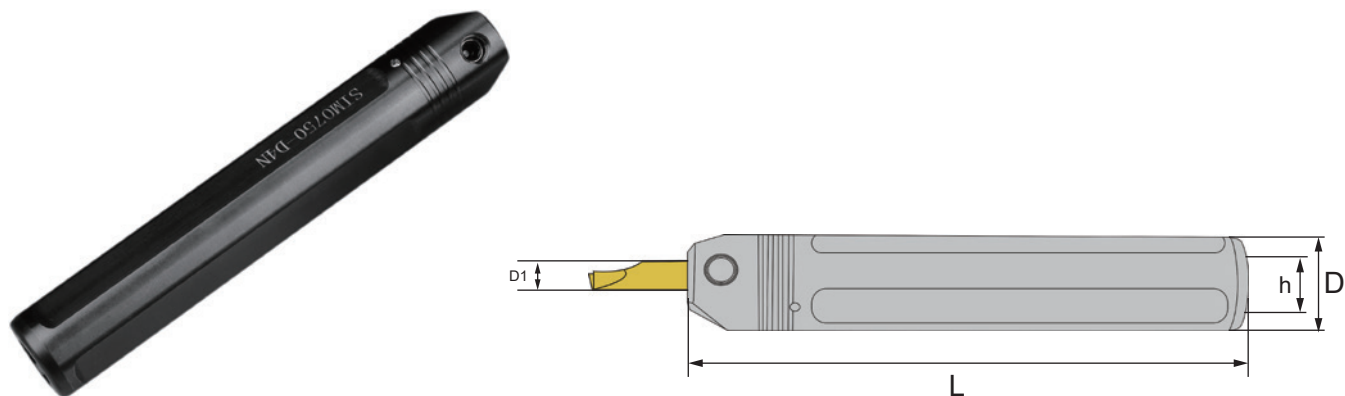

产品型号 ProductType	D	D1	L	h	锁紧螺钉 Clamping Screw
SIM0012-D4	12	4	75	10.6	T0608
SIM0012-D5	12	5	75	10.6	T0608
SIM0012-D6	12	6	75	10.6	T0608
SIM0016-D4	16	4	90	14.6	T0608
SIM0016-D5	16	5	90	14.6	T0608
SIM0016-D6	16	6	90	14.6	T0608
SIM0016-D7	16	7	90	14.6	T0608
SIM0750-D4	19.05	4	90	17.8	T0608
SIM0750-D5	19.05	5	90	17.8	T0608
SIM0750-D6	19.05	6	90	17.8	T0608
SIM0750-D7	19.05	7	90	17.8	T0608
SIM0020-D4	20	4	90	18	T0608
SIM0020-D5	20	5	90	18	T0608
SIM0020-D6	20	6	90	18	T0608
SIM0020-D7	20	7	90	18	T0608
SIM0022-D4(130)	22	4	130	20.6	T0608
SIM0022-D5(130)	22	5	130	20.6	T0608
SIM0022-D6(130)	22	6	130	20.6	T0608
SIM0022-D7	22	7	90	20.6	T0608
SIM0025-D4	25	4	90	23	T0608
SIM0025-D5	25	5	90	23	T0608
SIM0025-D6	25	6	90	23	T0608
SIM0025-D7	25	7	90	23	T0608
SIM1000-D4	25.4	4	90	23	T0608
SIM1000-D5	25.4	5	90	23	T0608
SIM1000-D6	25.4	6	90	23	T0608
SIM1000-D7	25.4	7	90	23	T0608

STAR TINY TOOLS TOOLHOLDERS FOR MACHINES



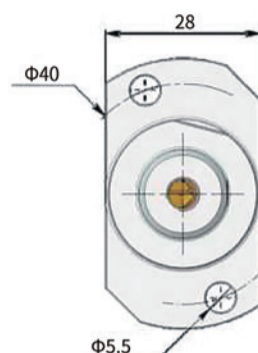
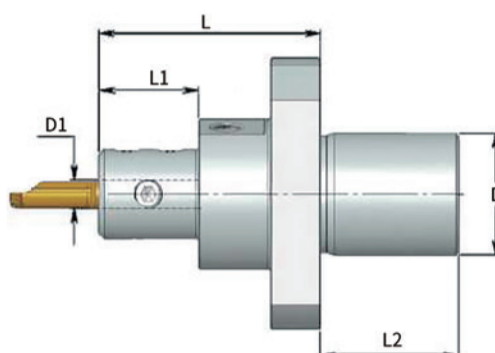



STAR机床微型变径套刀杆



产品型号 Product Type	D	D1	L	L1	L2	dp 水管孔Hole Tube	锁紧螺钉 clamping screw
SIM22S-D4	22	4.0	52	30	25	6.0	T0608
SIM22S-D5	22	5.0	52	30	25	6.0	T0608
SIM22S-D6	22	6.0	52	30	25	6.0	T0608
SIM22S-D7	22	7.0	52	30	25	6.0	T0608

COATING ITEM

涂层说明

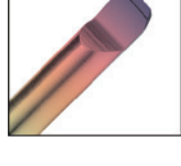
Coated Item 涂层编号	Color 颜色	Application 加工材料	Performance parameter 特性参数
AT12	Gold 金色 	Universal use for ≤HRC45 material; Stainless(austenitic&Martensite,303,304,316F...); Steel(Bearing steel, quenched steel, Cr-Mo steel, Mn steel...); Koveralloy; Superalloy;Copper; Iron castingPig iron; Nickel alloy,PMMA... 泛用于HRC45以内材料, 包括但不限于: 奥氏体/马氏体不锈钢,303,316F,镍不锈钢等; 钢材(淬火钢, 洛钼钢, 锰钢等碳钢); 生铁, 铸铁, 镍合金, 亚克力等。	Nano Hardness :HV3500 Friction Coefficient: 0.3 Max.Temp: 900°
JS25	Bronze 古铜色 	Universal use for ≤HRC60 material; Stainless(austenitic&Martensite,316L 303,304,321,316F,High Nickel Stainless...); Steel(Bearing steel,quenched steel,Cr-Mo steel,Mn steel...); Koveralloy; Superalloy;Copper; Iron castingPig iron; Nickel alloy.. 泛用于HRC60以内材料, 包括但不限于: 奥氏体/马氏体不锈钢,316L,303,321,316F,高镍不锈钢等; 钢材(轴承钢, 淬火钢, 洛钼钢, 锰钢等高碳钢); 可伐合金; 高温合金; 生铁, 铸铁, 镍合金等。	Nano Hardness :HV4500, Friction Coefficient: 0.4 Max.Temp: 1100°
AL25	Blue Grey 黑蓝色 	Special use for mild material ; Especial for Pure iron , special for mild steel & mild stainless,like 304. 特别用于低碳材料, 尤其纯铁; 适用于低碳钢和低碳不锈钢, 比如304不锈钢	Nano Hardness :HV3500, Friction Coefficient: 0.25 Max.Temp: 800°
AD12	Black 黑色 	Special use for viscous Material;; Aluminium, PMMA, Polyethylene.CFRP. 粘材专用, 尤其铝材、亚克力、聚乙烯, 碳纤维材料。	Nano Hardness :HV2200, Friction Coefficient: 0.2 Max.Temp: 400°
TZ25	Champagne Gold 香槟金色 	Special use for titanium alloy. 钛合金专用。	Nano Hardness :HV4000 Friction Coefficient: 0.55 Max.Temp: 900°
AT25	Black 黑色 	Carbon Steel,alloy steel,Bearing steel, quenched steel,Cr-Mo steel,Mn steel...; 碳素钢,合金钢,轴承钢,淬火钢,洛钼钢,锰钢等等	Nano Hardness :HV3500, Friction Coefficient: 0.6 Max.Temp: 900°
LC25	Rainbow 七彩色 	Special use for viscous Material;; Aluminium, PMMA, Polyethylene.CFRP. 粘材专用, 尤其铝材、亚克力、聚乙烯, 碳纤维材料。	Nano Hardness :HV5000 Friction Coefficient: 0.05 Max.Temp: 450°